

Erde/Wasser Wärmepumpe FEW 1-6 bis 2-80 - Massblatt

Standard:
Sole Links 1 2 3 4 5 **Heizung Rechts**
Variante:
Heizung Links 5 4 3 2 1 **Sole Rechts**

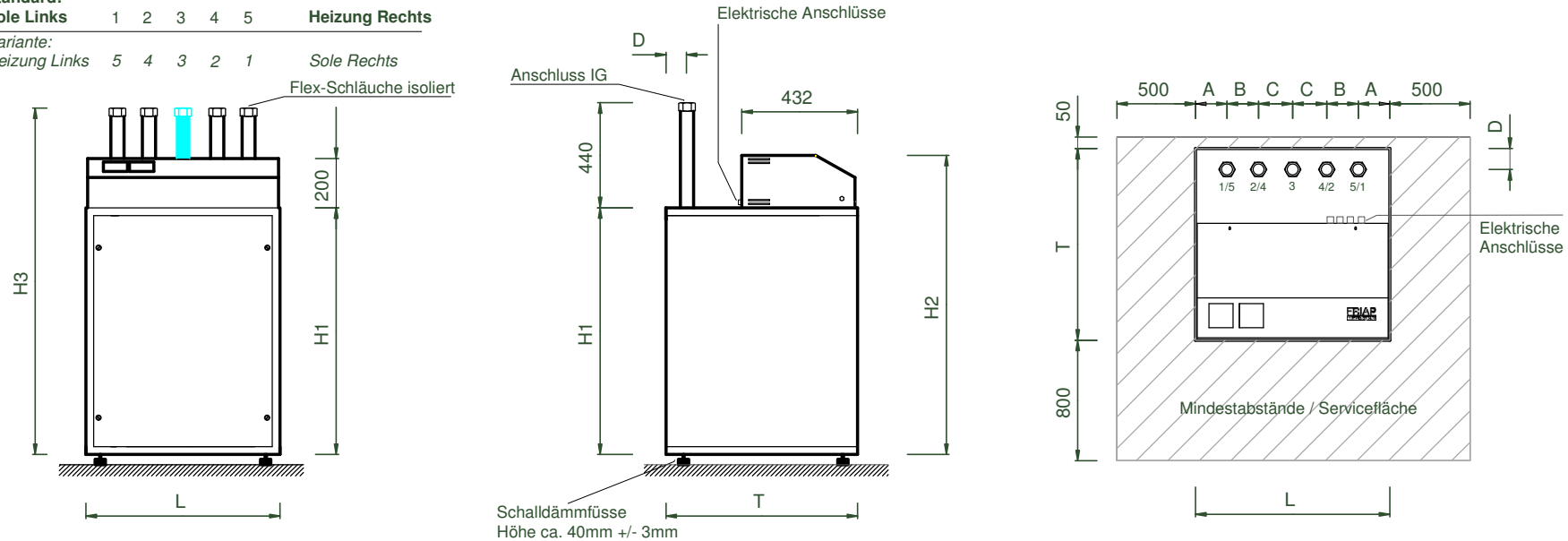

Typ	Leistungsangaben			Bauseitige Absicherung	Anschlüsse					Abmessungen in [mm]					Gewicht	Volumenstrom		Druckverlust					
	Heizleistung B 0°/W35	Kälteleistung B 0°/W35	Aufnahmeleis. B 0°/W35		1 Sole Aus	2 Sole Ein	3 VL BWW	4 Heiz. VL	5 Heiz. RL	L	T	H1	H2	H3		A	B	C	D	in [kg]	Verdampfer [m ³ /h]	Kondensator [m ³ /h]	Verdampfer [kPa]
FEW 1-6	6.50 [kW]	5.0 [kW]	1.60 [kW]	16 [AT]	5/4" - IG	5/4" - IG	1" - IG	1" - IG	1" - IG	540	600	940	1120	1380	85	90	95	80	120	1.53	1.10	20	5
FEW 1-8	7.20 [kW]	5.60 [kW]	1.60 [kW]	16 [AT]	5/4" - IG	5/4" - IG	1" - IG	1" - IG	1" - IG	540	600	940	1120	1380	85	90	95	80	130	1.72	1.20	20	5
FEW 1-10	9.50 [kW]	7.20 [kW]	2.30 [kW]	16 [AT]	5/4" - IG	5/4" - IG	1" - IG	1" - IG	1" - IG	540	600	940	1120	1380	85	90	95	80	135	2.20	1.60	25	5
FEW 1-12	10.50 [kW]	8.20 [kW]	2.40 [kW]	16 [AT]	5/4" - IG	5/4" - IG	1" - IG	1" - IG	1" - IG	740	730	940	1140	1380	120	120	130	80	140	2.51	1.80	25	5
FEW 1-14	12.90 [kW]	10.20 [kW]	2.90 [kW]	20 [AT]	1 1/2" - IG	1 1/2" - IG	1" - IG	1" - IG	1" - IG	740	730	940	1140	1380	120	120	130	80	145	3.13	2.20	25	5
FEW 1-17	15.40 [kW]	12.20 [kW]	3.40 [kW]	20 [AT]	1 1/2" - IG	1 1/2" - IG	-	5/4" - IG	5/4" - IG	740	730	940	1140	1380	120	120	130	80	170	4.03	2.60	20	15
FEW 1-21	19.60 [kW]	15.10 [kW]	4.70 [kW]	25 [AT]	2" - IG	2" - IG	-	5/4" - IG	5/4" - IG	740	730	940	1140	1380	120	120	130	80	215	4.98	3.40	20	15
FEW 1-27	29.00 [kW]	21.90 [kW]	7.10 [kW]	32 [AT]	2" - IG	2" - IG	-	1 1/2" - IG	1 1/2" - IG	900	790	1040	1240	1480	100	160	190	100	260	7.27	5.10	25	15
FEW 1-34	33.80 [kW]	26.40 [kW]	7.80 [kW]	32 [AT]	2" - IG	2" - IG	-	1 1/2" - IG	1 1/2" - IG	900	790	1040	1240	1480	100	160	190	100	400	8.71	5.70	20	15
FEW 2-40	39.20 [kW]	30.40 [kW]	9.40 [kW]	40 [AT]	2 1/2"	2 1/2"	-	2" - IG	2" - IG	1300	790	1040	1240	1480	100	150	400	200	450	10.03	3.35	20	5
FEW 2-50	55.00 [kW]	43.20 [kW]	12.60 [kW]	50 [AT]	2 1/2"	2 1/2"	-	2" - IG	2" - IG	1300	790	1040	1240	1480	100	150	400	200	520	14.26	4.71	20	5
FEW 2-65	67.60 [kW]	52.80 [kW]	15.40 [kW]	60 [AT]	2 1/2"	2 1/2"	-	2" - IG	2" - IG	1300	790	1040	1240	1480	100	150	400	200	590	17.43	5.78	25	5
FEW 2-80	82.20 [kW]	64.20 [kW]	19.00 [kW]	80 [AT]	3"	3"	-	2 1/2"	2 1/2"	1300	790	1040	1240	1480	100	150	400	200	640	21.19	7.03	25	5

friap@friap.ch www.friap.ch

FRIAP AG

Ey 9
 3063 Ittigen
 Tel. 031 917 51 11
 Fax 031 917 51 10

FRIAP AG

Bleicheweg 5
 5605 Dottikon
 Tel. 056 616 77 00
 Fax 056 616 77 19

FRIAP AG

n-energetechnik
 Felsenastrasse 31
 7001 Chur
 Tel. 081 252 81 20
 Fax 081 252 81 21

FRIAP SA

Ch. des Biollettes 13
 1680 Romont FR
 Tel. 026 652 90 50
 Fax 026 652 90 59